

SMF4L Series

Description

The SMF4L series are designed to protect voltage sensitive components from high voltage, high energy transients. Excellent clamping capability, high surge capability, low zener impedance and fast response time. Because of its small size, it is ideal for use in cellular phones, portable device, business machines, power supplies and many other industrial/consumer applications.

Features

- IEC61000-4-2 ESD 30KV Air, 15KV contact compliance
- SOD-123FL surface mount package
- Protects one I/O line
- Peak power dissipation of 2000W under 8/20 μ s waveform
- Working voltage: 5V~85V
- Low leakage current
- Solid-state silicon avalanche technology
- Lead Free/RoHS compliant
- Solder reflow temperature: Pure Tin-Sn, 260~270 $^{\circ}$ C
- Flammability rating UL 94V-0
- Meets MSL level 1, per J-STD-020
- AEC-Q101 qualified (Automotive grade with suffix "Q".)
- Expsemi electronics

Applications

- Personal digital assistants (PDA)
- Cellular handsets & Accessories
- Portable devices
- Portable instrumentation
- Handhelds and notebooks
- Digital cameras

Maximum Ratings

Rating	Symbol	Value	Unit
Peak pulse power (tp=10/1000 μ s waveform)	P_{PP}	400	W
Peak pulse power (tp=8/20 μ s waveform)	P_{PP}	2000	W
ESD voltage (Contact discharge)	V_{ESD}	± 30	kV
ESD voltage (Air discharge)		± 15	
Storage & operating temperature range	T_{STG}, T_J	-65~+150	$^{\circ}$ C

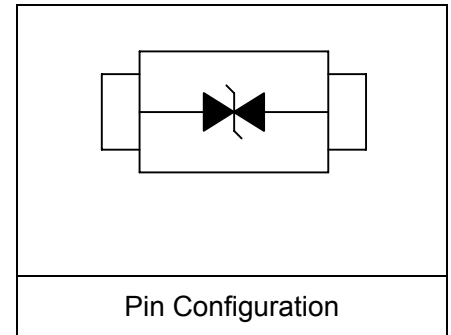

Electrical Characteristics

Type Number		Device Marking Code		Reverse Stand-Off Voltage	Breakdown Voltage@IT		Test Current	Maximum Clamping Voltage @Ipp	Peak Pulse Current	Reverse Leakage @VR
UNI	BI	UNI	BI	VR(V)	VBR MIN.(V)	VBR MAX.(V)	T(mA)	VC(V)	Ipp(A)	IR(μA)
SMF4L5.0A	SMF4L5.0CA	EHE	ETE	5.0	6.40	7.25	10	9.2	40.1	400
SMF4L6.0A	SMF4L6.0CA	EHG	ETG	6.0	6.67	7.67	10	10.3	35.9	400
SMF4L6.5A	SMF4L6.5CA	EHK	ETK	6.5	7.22	8.30	10	11.2	33.1	250
SMF4L7.0A	SMF4L7.0CA	EHM	ETM	7.0	7.78	8.95	10	12.0	30.9	100
SMF4L7.5A	SMF4L7.5CA	EHP	ETP	7.5	8.33	9.58	1	12.9	28.7	50
SMF4L8.0A	SMF4L8.0CA	EHR	ETR	8.0	8.89	10.23	1	13.6	27.2	25
SMF4L8.5A	SMF4L8.5CA	EHT	ETT	8.5	9.44	10.82	1	14.4	25.7	10
SMF4L9.0A	SMF4L9.0CA	EHV	ETV	9.0	10.00	11.50	1	15.4	24.1	5.0
SMF4L10A	SMF4L10CA	EHX	ETX	10.0	11.10	12.80	1	17.0	23.5	2.5
SMF4L11A	SMF4L11CA	EHZ	ETZ	11.0	12.20	14.00	1	18.2	22.0	2.5
SMF4L12A	SMF4L12CA	EIE	EUE	12.0	13.30	15.30	1	19.9	20.1	2.5
SMF4L13A	SMF4L13CA	EIG	EUG	13.0	14.40	16.50	1	21.5	18.6	1
SMF4L14A	SMF4L14CA	EIK	EUK	14.0	15.60	17.90	1	23.2	17.2	1
SMF4L15A	SMF4L15CA	EIM	EUM	15.0	16.70	19.20	1	24.4	16.4	1
SMF4L16A	SMF4L16CA	EIP	EUP	16.0	17.80	20.50	1	26.0	15.4	1
SMF4L17A	SMF4L17CA	EIR	EUR	17.0	18.90	21.70	1	27.6	14.5	1
SMF4L18A	SMF4L18CA	EIT	EUT	18.0	20.00	23.30	1	29.2	13.7	1
SMF4L20A	SMF4L20CA	EIV	EUV	20.0	22.20	25.50	1	32.4	12.3	1
SMF4L22A	SMF4L22CA	EIX	EUX	22.0	24.40	28.00	1	35.5	11.3	1
SMF4L24A	SMF4L24CA	EIZ	EUZ	24.0	26.70	30.70	1	38.9	10.3	1
SMF4L26A	SMF4L26CA	EJE	EVE	26.0	28.90	33.20	1	42.1	9.5	1
SMF4L28A	SMF4L28CA	EJG	EVG	28.0	31.10	35.80	1	45.4	8.8	1
SMF4L30A	SMF4L30CA	EJK	EVK	30.0	33.30	38.30	1	48.4	8.3	1
SMF4L33A	SMF4L33CA	EJM	EVM	33.0	36.70	42.20	1	53.3	7.5	1
SMF4L36A	SMF4L36CA	EJP	EVP	36.0	40.00	46.00	1	58.1	6.9	1
SMF4L40A	SMF4L40CA	EJR	EVR	40.0	44.40	51.10	1	64.5	6.2	1
SMF4L43A	SMF4L43CA	EJT	EVT	43.0	47.80	54.90	1	69.4	5.8	1
SMF4L45A	SMF4L45CA	EJV	EVV	45.0	50.00	57.50	1	72.7	5.5	1
SMF4L48A	SMF4L48CA	EJX	EVX	48.0	53.30	61.30	1	77.4	5.2	1
SMF4L51A	SMF4L51CA	EJZ	EVZ	51.0	56.70	65.20	1	82.4	4.9	1
SMF4L54A	SMF4L54CA	ERE	EWE	54.0	60.00	69.00	1	87.1	4.6	1
SMF4L58A	SMF4L58CA	ERG	EWG	58.0	64.40	74.10	1	93.6	4.3	1
SMF4L60A	SMF4L60CA	ERK	EWK	60.0	66.70	76.70	1	96.8	4.1	1
SMF4L64A	SMF4L64CA	ERM	EWM	64.0	71.10	81.80	1	103.0	3.9	1
SMF4L70A	SMF4L70CA	ERP	EWP	70.0	77.80	89.50	1	113.0	3.5	1
SMF4L75A	SMF4L75CA	ERR	EWR	75.0	83.30	95.80	1	121.0	3.3	1
SMF4L78A	SMF4L78CA	ERT	EWT	78.0	86.70	99.70	1	126.0	3.2	1
SMF4L85A	SMF4L85CA	ERV	EWV	85.0	94.40	108.20	1	137.0	2.9	1

I-V Curve Characteristics

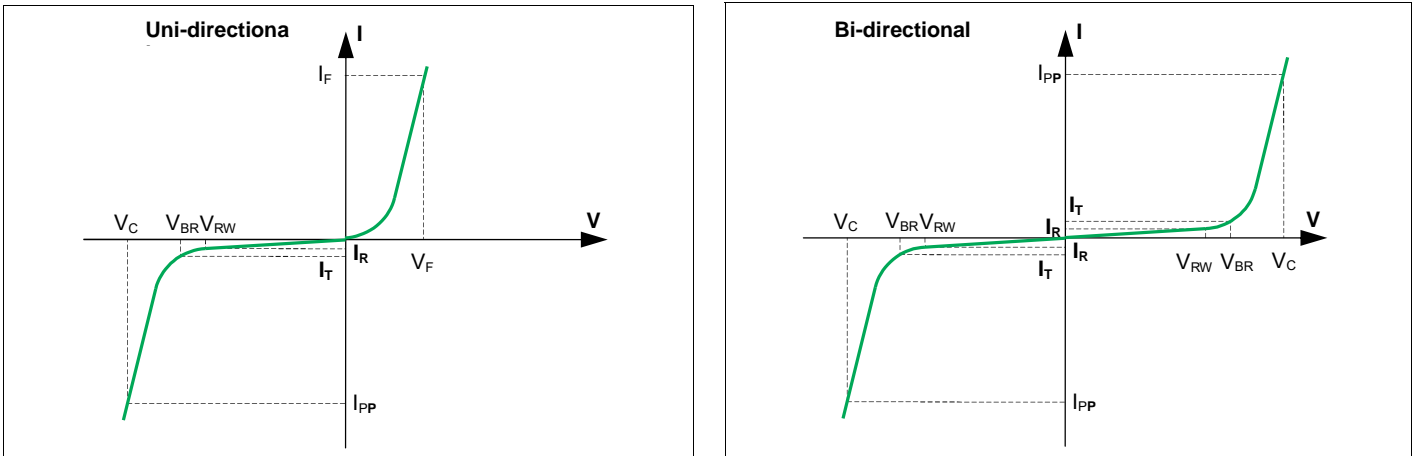

- P_{PPM} Peak Pulse Power Dissipation** -- Max power dissipation
- V_R Stand-off Voltage** -- Maximum voltage that can be applied to the TVS without operation
- V_{BR} Breakdown Voltage** -- Maximum voltage that flows through the TVS at a specified test current (I_T)
- V_C Clamping Voltage** -- Peak voltage measured across the TVS at a specified I_{ppm} (peak impulse current)
- I_R Reverse Leakage Current** -- Current measured at V_R
- V_F Forward Voltage Drop for Uni-directional**

Ratings and Characteristic Curves ($T_A=25^\circ\text{C}$ unless otherwise noted)

Figure 1 - TVS Transients Clamping Waveform

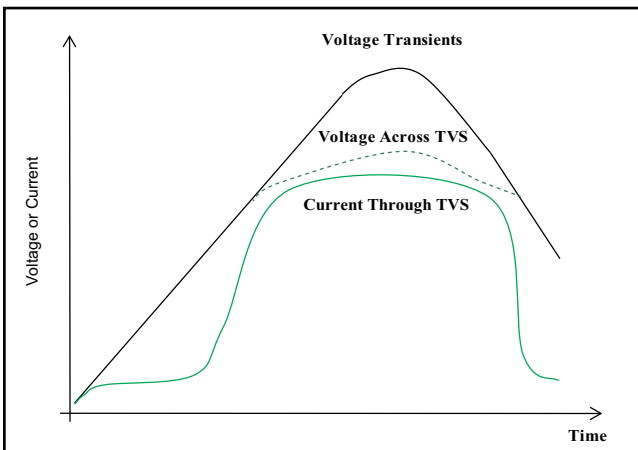
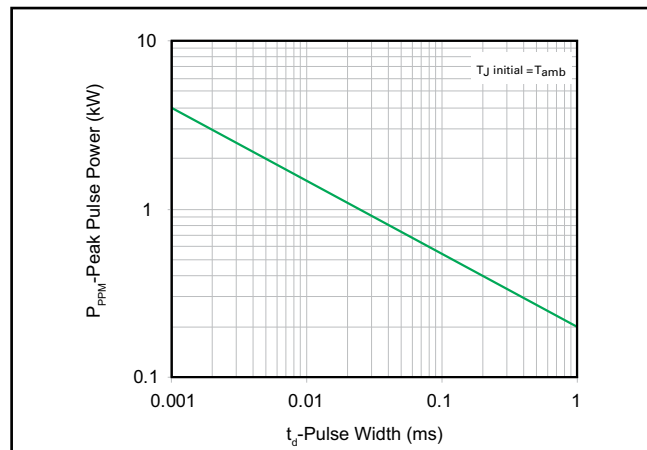

Figure 2 - Peak Pulse Power Rating Curve



Ratings and Characteristic Curves ($T_A=25^\circ\text{C}$ unless otherwise noted) (Continued)

Figure 3 - Peak Pulse Power Derating Curve

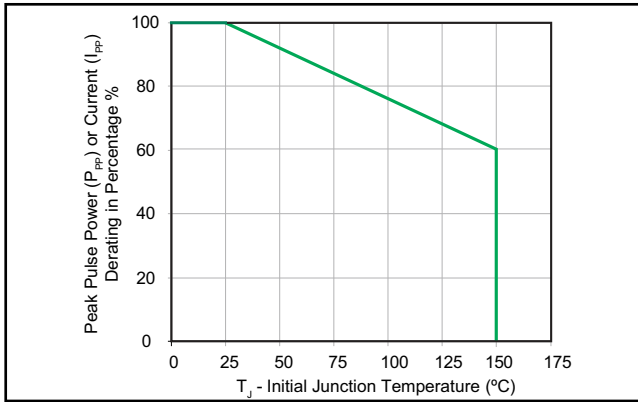

Figure 5 - Forward Voltage

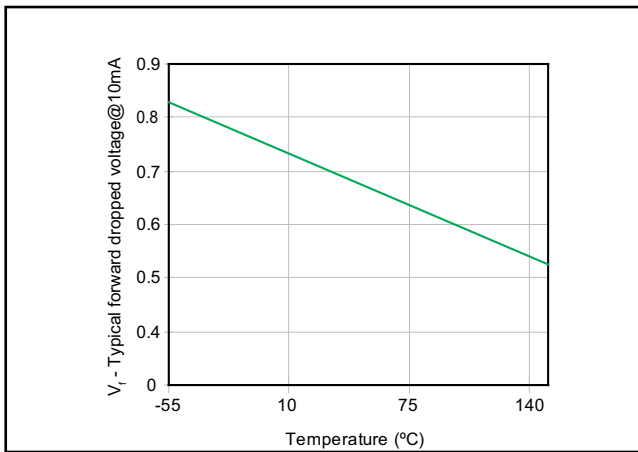

Figure 7 - Peak Forward Voltage Drop vs. Peak Forward Current

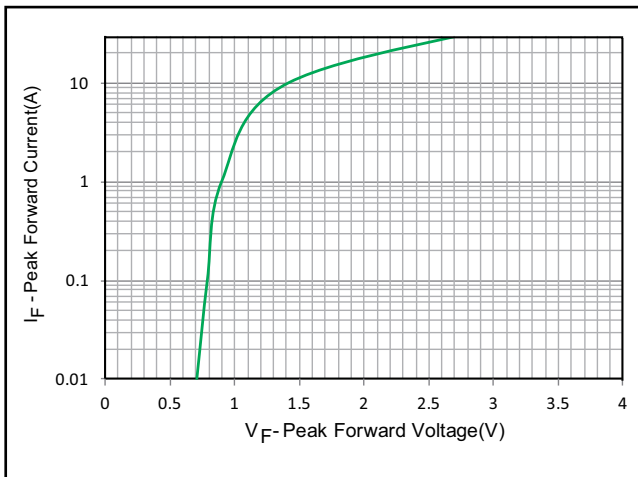

Figure 4 - Pulse Waveform - 10/1000μS

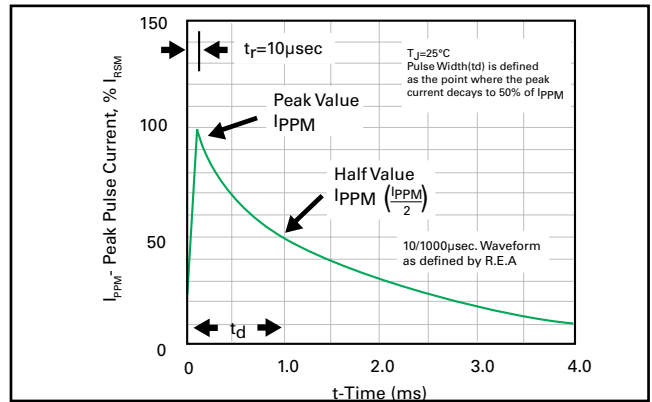

Figure 6 - Typical Junction Capacitance

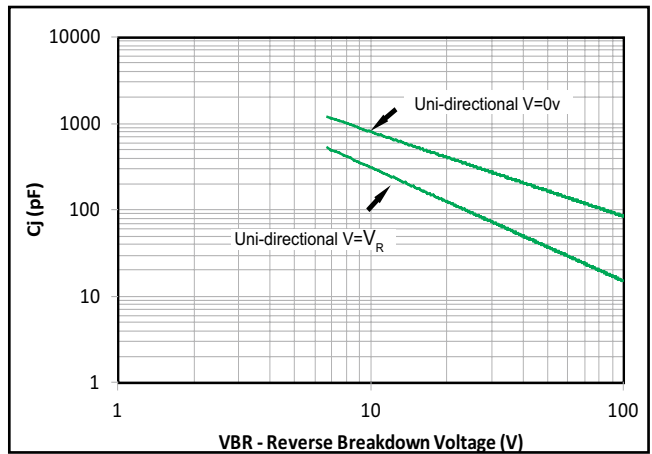
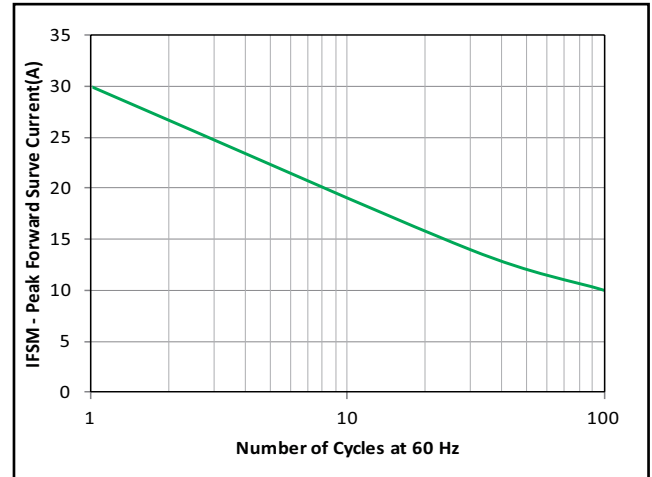
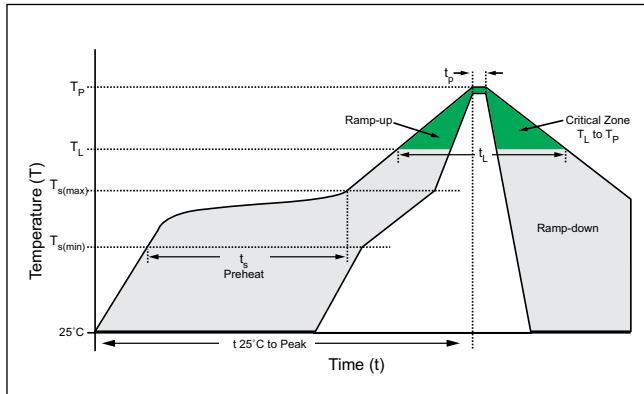

Figure 8 - Maximum Non-Repetitive Forward Surge Current Uni-Directional Only



Soldering Parameters

Reflow Condition		Lead-free assembly
Pre Heat	- Temperature Min ($T_{s(min)}$)	150°C
	- Temperature Max ($T_{s(max)}$)	200°C
	- Time (min to max) (t_s)	60 – 180 secs
Average ramp up rate (Liquidus Temp (T_A) to peak)		3°C/second max
$T_{s(max)}$ to T_A - Ramp-up Rate		3°C/second max
Reflow	- Temperature (T_A) (Liquidus)	217°C
	- Time (min to max) (t_s)	60 – 150 seconds
Peak Temperature (T_p)		260 ^{+0/-5} °C
Time within 5°C of actual peak Temperature (t_p)		20 – 40 seconds
Ramp-down Rate		6°C/second max
Time 25°C to peak Temperature (T_p)		8 minutes Max.
Do not exceed		260°C



Physical Specifications

Case	SOD-123FL plastic over glass passivated junction
Polarity	Color band denotes cathode except bipolar
Terminal	Matte tin-plated leads, solderable per JESD22-B102

Environmental Specifications

High Temp. Storage	JESD22-A103
HTRB	JESD22-A108
Temperature Cycling	JESD22-A104
MSL	JEDEC-J-STD-020, Level 1
H3TRB	JESD22-A101
RSH	JESD22-A111

Dimensions - SOD-123FL Package

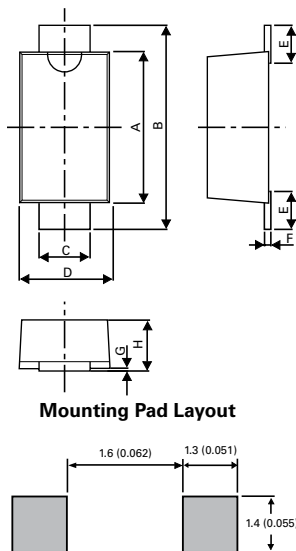

Dimensions	Millimeters		Inches	
	Min	Max	Min	Max
A	2.50	3.00	0.0984	0.1182
B	3.40	3.90	0.1339	0.1535
C	0.70	1.35	0.0275	0.0531
D	1.50	2.00	0.0591	0.0787
E	0.35	0.90	0.0138	0.0354
F	0.05	0.26	0.0020	0.0102
G	0.00	0.10	0.000	0.0039
H	0.70	1.35	0.0275	0.0531

Part Numbering System

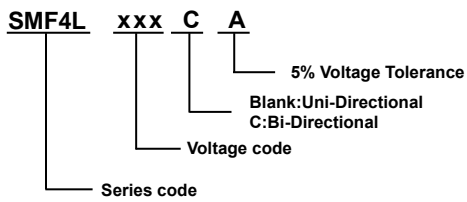

Packaging Options

Part number	Component Package	Quantity	Packaging Option	Packaging Specification
SMF4LxxXX	SOD-123FL	3000	Tape & Reel – 8mm tape/7" reel	EIA RS-481

Tape and Reel Specification

